

27" Countertop Heated Display Case

Model: RTR-120L



- *Tested to NSF Standard 7 requirements for open food storage.*
- *Sliding Door Design, The design of sliding doors can greatly save space for your store or restaurant.*
- *Our showcase has three adjustable chrome plated shelves.*
- *Digital Temperature Control, Our display case uses R290 refrigerant, which keeps the interior temperature at a safe level between 86°F - 194°F.*
- *Specially designed air outlets circulate air in front of the curved glass to reduce the accumulation of condensation.*
- *This crumb tray can effectively hold food crumbs.*
- *Air duct outside the glass to remove condensation water.*
- *Brilliant Internal LED illumination on top.*

27" Countertop Heated Display Case

Model: RTR-120L

•ETL Certified For Safety & Sanitation



MODEL	EXTERNAL DIMENSION (inches)	V/Hz/Ph	STORAGE CAPACITY L	DOORS	TEMPERATURE	REFRIGERANT	AMPS	RATED INPUT POWER W	NEMA PLUG	SHIPPING WEIGHT (lbs.)
RTR-120L	26 7/16 x 22 3/8 x 27	115/60/1	120	2	86°F to 194°F	R290	15	1800	5-15P	84

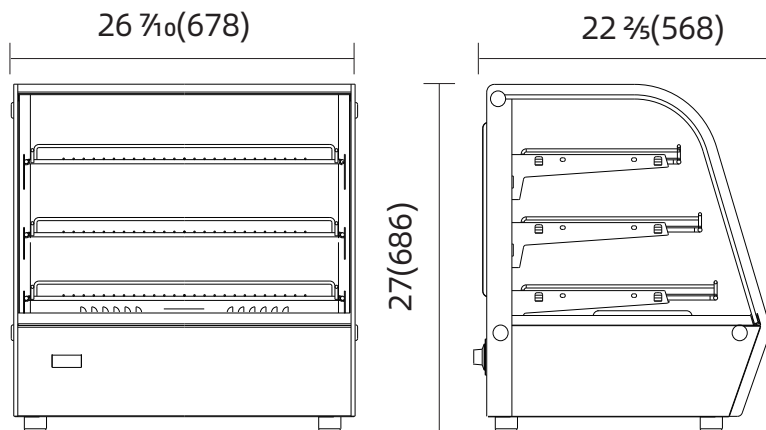

1 YEAR PARTS WARRANTY (NOT FOR RESIDENTIAL USE)

