

47 4/5" Countertop Heated Display Case

Model: RTR-186L



- *Tested to NSF Standard 7 requirements for open food storage.*
- *Sliding Door Design, The design of sliding doors can greatly save space for your store or restaurant.*
- *Includes 3 Adjustable Shelves
Our showcase has three adjustable chrome plated shelves.*
- *Digital Temperature Control, Our display case uses R290 refrigerant, which keeps the interior temperature at a safe level between 86°F - 194°F.*
- *This crumb tray can effectively hold food crumbs.*
- *Brilliant Internal LED illumination on top.*

47 4/5" Countertop Heated Display Case

Model: RTR-186L

•ETL Certified For Safety & Sanitation



MODEL	EXTERNAL DIMENSION (inches)	V/Hz/Ph	STORAGE CAPACITY L	DOORS	TEMPERATURE	REFRIGERANT	AMPS	RATED INPUT POWER W	NEMA PLUG	SHIPPING WEIGHT (lbs.)
RTR-186L	47 4/5 x 19 1/10 x 26 1/10	115/60/1	186	4	86°F to 194°F	R290	12.8	1500	5-15P	130

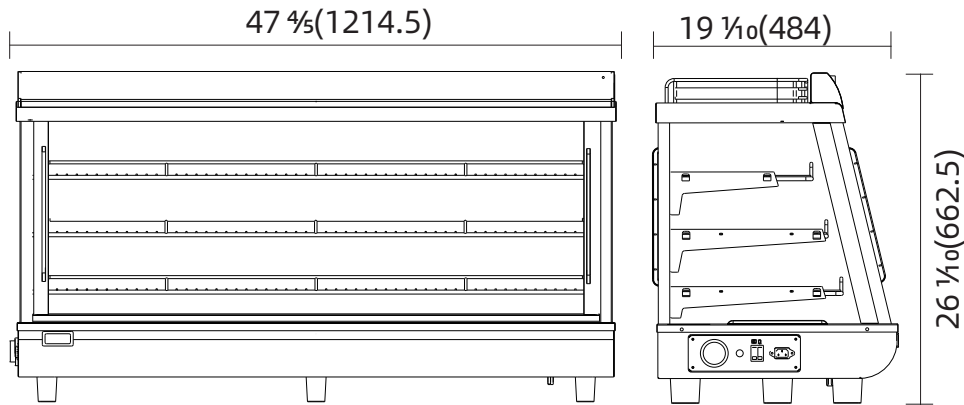

1 YEAR PARTS WARRANTY (NOT FOR RESIDENTIAL USE)



CHEFMIND GROUP INC.

SPECIFICATIONS SUBJECT TO CHANGE WITHOUT NOTICE