

18" Full-Service Countertop Display Warmer

Model: RTR-97L



- Tested to NSF Standard 7 requirements for open food storage.
- Adjustable temperature controller.
- Temperature display.
- 3 Adjustable chrome plated shelves.
- Back doors.
- Front top light box with decals.
- Can catch food crumbs and is easy to move and clean.

18" Full-Service Countertop Display Warmer

Model: RTR-97L

•ETL Certified For Safety & Sanitation



MODEL	EXTERNAL DIMENSION (inches)	V/Hz/Ph	STORAGE CAPACITY L	NET WEIGHT (lbs.)	TEMPERATURE	REFRIGERANT	AMPS	DOORS	NEMA PLUG	SHIPPING WEIGHT (lbs.)
RTR-97L	18 1/10 x 17 3/5 x 30 9/10	115/60/1	97	48.5	86°F to 194°F	R290	7.2	1	5-15P	53

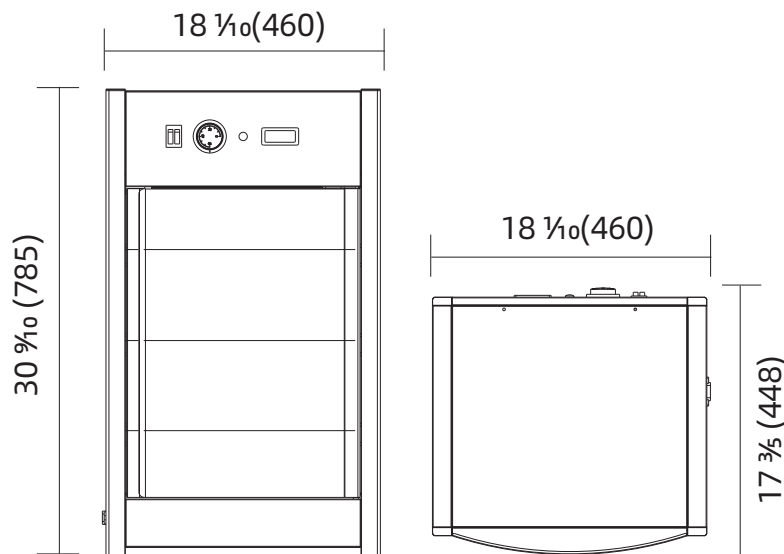

1 YEAR PARTS WARRANTY (NOT FOR RESIDENTIAL USE)



CHEFMIND GROUP INC.

SPECIFICATIONS SUBJECT TO CHANGE WITHOUT NOTICE