

## 35" Countertop Refrigerated Bakery

### Model: RTW-160L-5



- Tested to NSF Standard 7 requirements for open food storage.
- Sliding Door Design, The design of sliding doors can greatly save space for your store or restaurant.
- Includes 2 Adjustable Shelves  
Our showcase has two chrome wire interior shelves.
- Digital Temperature Control, Our display case uses R290 refrigerant, which keeps the interior temperature at a safe level between 32°F-53.6°F.
- Brilliant Internal LED illumination on top.
- Ventilated cooling system.
- Automatic Defrost.
- Air duct outside the glass to remove condensation water.

# 35" Countertop Refrigerated Bakery

## Model: RTW-160L-5

**•ETL Certified For Safety & Sanitation**



MODEL	EXTERNAL DIMENSION (inches)	V/Hz/Ph	STORAGE CAPACITY L	DOORS	TEMPERATURE	REFRIGERANT	AMPS	LAMP POWER W	NEMA PLUG	SHIPPING WEIGHT (lbs.)
RTW-160L-5	34 3/8 x 22 3/8 x 27	115/60/1	146	2	32°F to 53.6°F	R290	3	2(LED)	5-15P	154

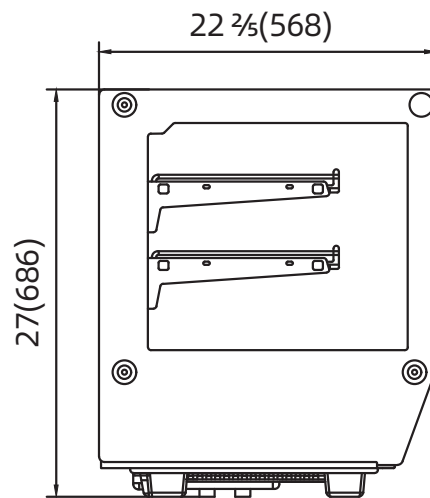
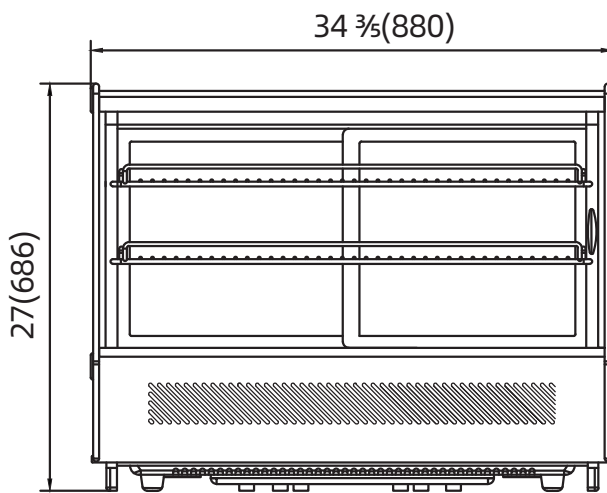

**1 YEAR PARTS WARRANTY (Not for Residential Use)**

